

The Leslie® X-77 L

GENERAL OPERATING AND MAINTENANCE INSTRUCTIONS

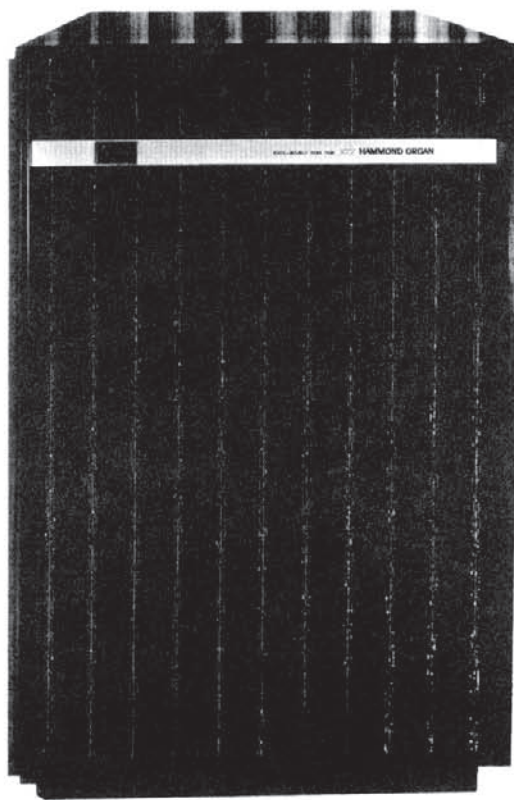

TO ORDER PARTS IN THIS SECTION REFER TO
MANUFACTURER AT ADDRESS BELOW:

ELECTRO-MUSIC, INC.
56 WEST DEL MAR BOULEVARD
PASADENA, CA 91105

Bin 30, Arroyo Annex
Pasadena, California 91109

ELECTRO MUSIC
A Division of Columbia Broadcasting Systems, Inc.
CBS Musical Instruments

Feb. 1969
023846

Introduction

THE LESLIE ORGAN SPEAKER MODEL X-77L

The Leslie X-77L is a 200-watt, four-channel speaker designed for use with the Hammond X-77 Model organ. The speaker incorporates four fifty-watt solid-state amplifier channels and six heavy-duty permanent magnet loudspeakers. Controls for the speaker are integral to the organ console. The block diagram below shows how the amplifier channels are connected to the speakers in the cabinet.

The vibrato channel drives the treble rotor speaker and the rotonomic drum. A crossover network directs all frequencies above 800 Hz. to the treble rotor driver, and all lower frequencies to the 6" x 9" speaker mounted in the rotonomic drum.

The non-vibrato channel drives the two stationary 6" x 9" speakers.

The pedal channel drives the 15-inch pedal speaker. Part of the higher-frequency pedal signal is routed

through the space generator, which drives the percussion amplifier and speaker.

The percussion channel drives the 8-inch percussion speaker.

When the Celeste tab is pressed down, the output of the non-vibrato amplifier is passed through a crossover network. This network passes frequencies above 800 Hz. to the rotating horn assembly. Frequencies below 800 Hz. drive the two stationary 6" x 9" speakers. The non-vibrato signal also passes through one channel of the space generator. The signal from the space generator is fed into the percussion amplifier, which drives the 8" percussion speaker.

NOTE: When the Celeste tab is depressed, the vibrato channel output bypasses the 800 Hz. crossover, and drives only the 6" x 9" speaker in the rotonomic drum.

BLOCK DIAGRAM

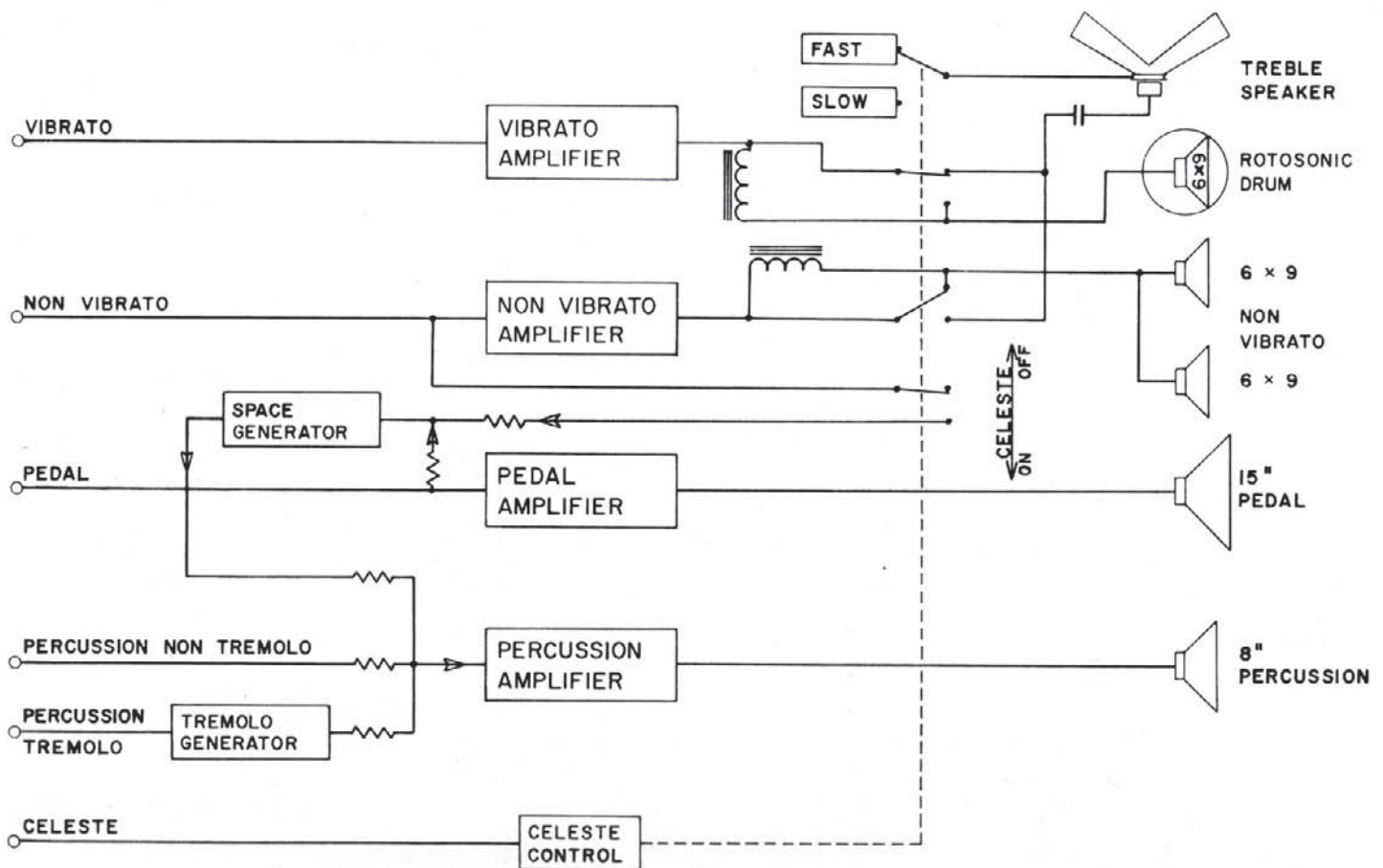

Fig. 1

SPECIFICATIONS

Cabinet Finish:	Selected hardwood veneers with a high-quality satin lacquer finish in wood grains and colors to harmonize with all organ consoles.
Cabinet Dimensions:	Height: 50¼" Width: 33¼" (front) 25" (back) Depth: 20½"
Speakers:	The X-77L contains six heavy-duty permanent-magnet loudspeakers.
Vibrato Channel: Treble Horn:	A 16 ohm compression-type driver carries the vibrato channel frequencies above 800 Hz.
Rotosonic Drum:	An 8 ohm 6" x 9" oval speaker mounted in the rotosonic drum handles vibrato channel frequencies below 800 Hz.
Non-Vibrato Channel:	Two 16 ohm 6" x 9" wide-range oval speakers carry the non-vibrato channel output.
Pedal Channel:	A 4 ohm, 15-inch bass speaker carries the low-frequency pedal tones. Part of the higher-frequency pedal signal is directed to the space generator, whose output is fed through the percussion amplifier and speaker.
Percussion Channel:	An 8 ohm, 8-inch wide-range speaker handles the percussion channel output. The percussion channel carries both the organ percussion signal and the higher-frequency pedal tones modified by the space generator.
Amplifier:	Four-channel 200 watt solid-state audio amplifier (50 watts per channel continuous undistorted output).
Power Requirement:	355 watts: 3.7 Amps @ 117V, 60 Hz. 1.8 Amps @ 234V, 50 Hz.
Amplifier Fuse:	2½ Ampere (117 V) 1½ Ampere (234 V)
Weight:	176 pounds (195 pounds packed for shipment)
Guarantee:	The speaker is guaranteed against all defects in materials and workmanship for one year from date of purchase. This guarantee does not cover belts or speaker cones, which may wear out sooner due to severe usage.

CONSOLE TAB CONTROLS

The Leslie Speaker functions are controlled by a bank of seven tabs at the organ console. When the control tabs on the console are in the "Up" position, the signal from both manuals is directed through the non-vibrato amplifier and speakers. Part of the higher pedal frequency range goes through the space generator, into the percussion amplifier and speaker. Pressing the tabs down causes the following changes in function:

SPEAKER CONTROL TAB SWITCHES AT X77 CONSOLE

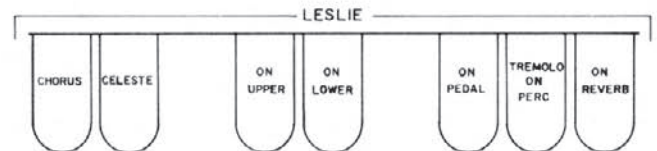

Fig. 2

ON UPPER:

Directs the upper manual signal to the vibrato amplifier and speakers.

ON LOWER:

Directs the lower manual signal to the vibrato amplifier and speakers.

ON REVERB:

Directs the reverberated signal from both manuals into the vibrato amplifier and speakers.

TREMOLO ON PERCUSSION:

Feeds the percussion signal through the percussion tremolo generator before it passes into the percussion amplifier and speaker.

ON PEDAL:

Transfers the entire pedal signal to the vibrato amplifier. Frequencies above 65 Hz. pass through the vibrato amplifier and speakers. Frequencies below 65 Hz. are bypassed back to the pedal amplifier and speaker.

CELESTE:

- Switches the treble horn from fast to slow speed.
- Directs the non-vibrato amplifier output above 800 Hz. through a crossover to the treble horn. Frequencies below 800 Hz. are passed to the two stationary 6" x 9" speakers.
- Feeds a portion of the non-vibrato signal through the space generator, which drives the percussion amplifier and speaker.
- If a vibrato tab is turned on while the celeste tab is down the entire vibrato output passes to the 6" x 9" speaker in the rotosonic drum.

CHORUS:

If the vibrato tab for either manual is down, depressing the "chorus" tab generates a "choral" or mixed vibrato effect by directing part of the vibrato channel signal through the non-vibrato amplifier and 6" x 9" speakers.

FOOT SWITCH: (located on left side of the expression pedal)

When this switch is pressed to the left, it eliminates organ vibrato by passing the signal from both manuals into the non-vibrato channel and speakers.

CELESTE CONTROL CIRCUIT

The Celeste control circuit is located in the power supply. The Celeste tab on the organ console grounds the Celeste control line, making Q7 and Q9 conduct. Q9's collector current closes the reed relay Rel-2, imposing a triggering bias on the gates of the bi-directional SCR switch D6/D7, which turns on the slow motor. The collector current of Q7 causes lamp M-1 to light. When R-108 is illuminated by M-1, its resistance drops from about 50 megohms to about 4K ohms, introducing the non-vibrato signal to the space generator. The increased voltage at the collector of Q7 shuts off Q8 and Q10.

When Q10 stops conducting, the reed relay Rel-3 opens, removing the triggering bias from the bidirec-

tional SCR switch D8/D9, which shuts off the fast motor. When Q8 stops conducting, it releases the speaker control relay Rel-1. This channels the vibrato output entirely to the rotonic drum, bypassing the low-pass filter L1. It also directs the high-frequency output of the non-vibrato channel to the treble horn through C8, and removes the shunt around L2, passing the low-frequency output to the two 6" x 9" non-vibrato speakers. Refer to the block diagram (p.1) and the schematic below.

NOTE: Under no circumstances should a load greater than 1 ampere be connected to either the fast or slow motor receptacles, or severe damage to the silicon controlled rectifiers D6, D7, D8, and D9 will result.

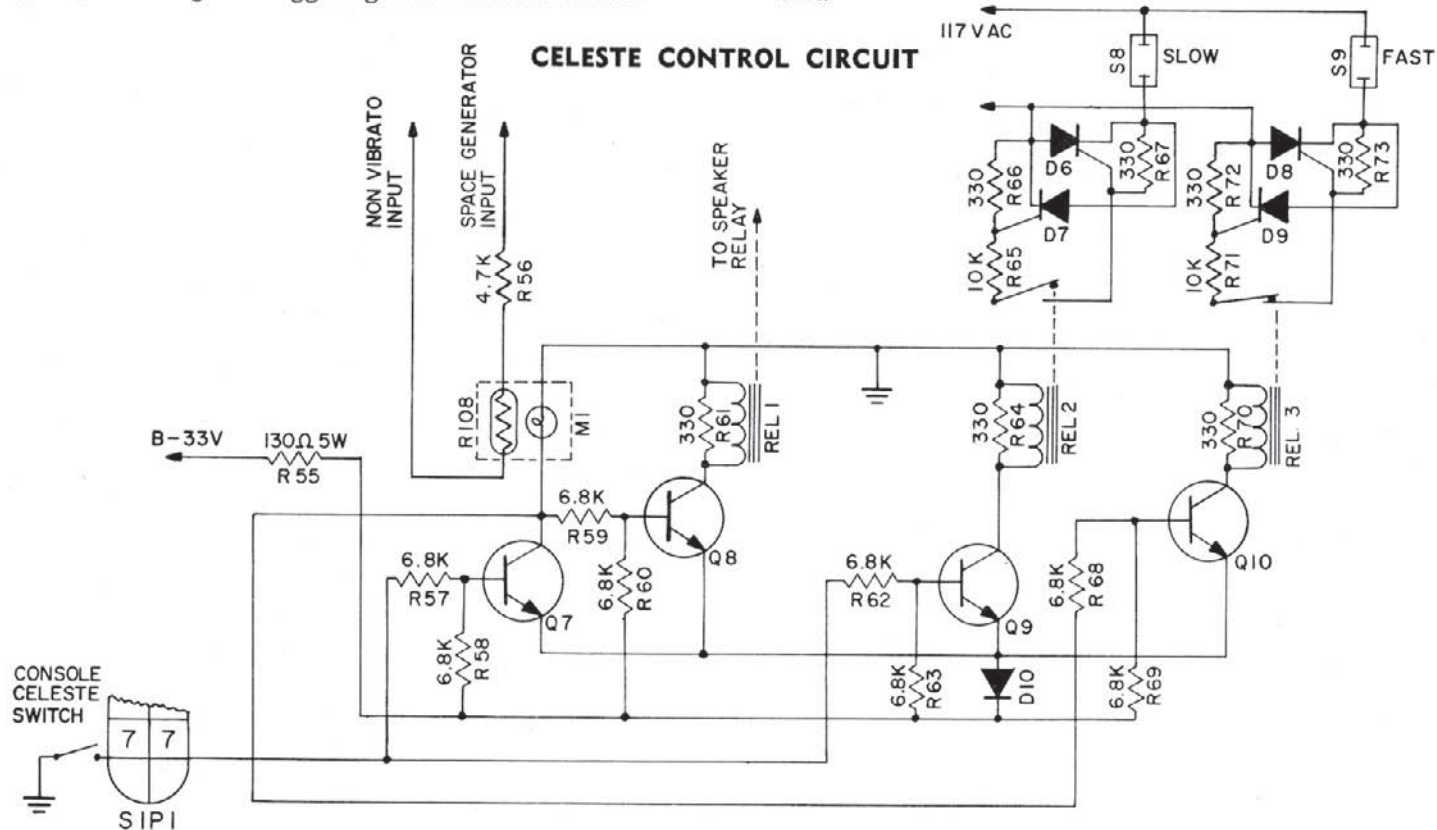

Fig. 3

Operation

UNPACKING SPEAKER

Remove the speaker from the carton and lay it on its face on a well-padded surface. Remove the bolts that secure the shipping skid to the base of the speaker, then set the cabinet upright. Remove the upper back panel and take out the rubber band securing the upper rotor, and the shipping blocks under the wing nut holding the motor assembly.

Replace the upper panel. Remove the lower panel and lay it flat. Pull out the corrugated pads above

and below the rotonic drum, and remove the shipping blocks under the wing nut securing the motor.

Replace the lower panel, connect the cable socket to the 12-contact plug on the amplifier, and plug the other end of the cable into the organ console. The speaker is now ready to operate.

NOTE: If the installation uses only one tone cabinet, be sure the cable connector is plugged into the "Main" socket of the console just to the left of the fuseholder.

CONNECTING CABLE

A standard 30-foot connecting cable is furnished with this unit. If the console and speaker must be separated by more than this distance, two or more of these standard cables may be connected in series.

Connecting cables of other lengths may be made up from bulk 9-conductor cable and special 12-pin plug and socket assemblies. The necessary parts may be obtained from Electro Music. Cable connections should be made in accordance with the diagram to the right. The color coding should be followed exactly, with special attention given to those connections which carry the line voltage.

MULTIPLE SPEAKER INSTALLATION

The X-77 Organ console provides switching and tone cabinet connectors for both a "Main" and an "Echo" tone cabinet. Two tone cabinets, furnishing 400 watts of audio power, can be connected to the organ without any additional provisions.

When requirements of volume and sound distribution exceed what can be obtained from two X-77L tone cabinets, additional speakers should be used to maintain proper balance. Each additional speaker is connected to another tone cabinet through a Leslie #031856 power relay. The power relay provides a source of AC power independent of the organ console for each additional cabinet. The added cabinet is controlled by the console Off/On Switch through the relay in the adapter.

Procedure

1. Connect the Leslie Speaker cable to the power relay;
2. Connect the power relay pigtail to the speaker;
3. Plug the connecting cable for the additional speaker into the receptacle on the power relay;
4. Plug the line cord from the power relay into the nearest AC outlet.

This procedure should be followed, using an additional power relay, for each tone cabinet added to the system.

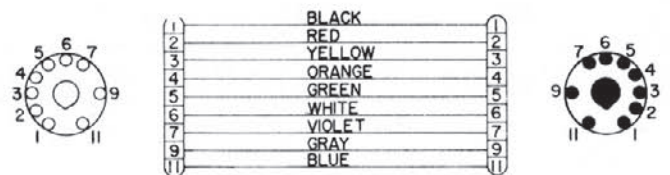

022871 Cable

Fig. 4

SPECIAL USES OF THE LESLIE

Broadcasting and Recording

When a Leslie Speaker is used in a broadcast or recording set-up, allowance must be made for the limitations of the microphone. The microphone will not pick up exactly the same sound and effects heard in the studio. The ideal set-up can only be accomplished by experiment. Here are a few general recommendations for recording and broadcasting:

1. Select a fairly "live" studio;
2. Play the organ at medium to full volume level;
3. Place the microphone ten to fifteen feet from the Leslie;
4. Do not place the microphone at the same height as the upper speaker.

Non-Organ Use of the Leslie Speaker

The Leslie Speaker is a high-quality product, designed expressly for use with electric organs and other musical instruments. The unique musical characteristics of this speaker are the result of electrical and acoustical properties very different from those in "high-fidelity" sound equipment. The speaker will function satisfactorily only in its intended use as a musical instrument, and no other applications are recommended.

SHIPPING

The Leslie Speaker may be moved or carried in any position without special preparation. If it is to be shipped, however, the cabinet should be kept in an upright position, with shipping blocks in place to protect the motors and rotors.

Service

MAINTENANCE

The Leslie Speaker is carefully engineered for durability and maximum service. Except for lubrication and periodic checking of the belts, the Leslie requires little attention.

Caution: Extreme care should be taken to keep hands and tools away from the spinning rotors when adjustments are made inside the cabinet. Because of the rotors' weight and momentum, there is some danger of injury to the serviceman, or to the Leslie components.

NOTE: The cable connecting the organ console and the Leslie Speaker should be connected and disconnected only while the console is turned off.

Line Voltage

Line voltage lower than 100 volts (200 volts in 234-volt model) will result in distortion and a lack of power. A supply voltage in excess of 130 volts (260 volts in 234-volt model) will cause overheating and possible component damage. A voltage-regulating device should be used if the line voltage varies beyond these limits. See page 18 for conversion of 234-volt cabinet to 250 volts.

Fuse

The amplifier uses a 2½ amp fuse for protection against overloads (1½ amp in 234 V. model). A blown fuse should be replaced only after the overload has been eliminated. **Never use a replacement fuse with a rating higher than this.**

Ordering Parts:

Standard hardware, connectors, and electronic components may be obtained locally. Non-standard items may be obtained through a Leslie speaker dealer, or from Electro Music. Orders should include part numbers, as given in the Speaker Parts Identification Chart. Model and serial numbers should also be included.

DRIVE BELTS

Four belts are used in the X-77L. If a belt becomes worn enough to produce objectionable noise, or if it breaks, it will have to be replaced.

Treble Rotor Belt Replacement

1. Remove the upper back panel;
2. Disengage the spring-loaded idler from the belt;
3. Lift the belt off the motor pulley;
4. Pull the belt over first one, then the other horn of the treble rotor.
5. To install the new belt, remove it from the package and pre-stretch it by pulling it out to full length. Slip it over the treble rotor, one horn at a time, and follow the steps taken in removing the belt in reverse.

Space Generator Belt Removal

Upper Belt

1. Remove the center back panel;
2. Pull the mercotac off shaft (E);
3. Pull idler (D) counterclockwise and remove the upper belt from pulleys (C) and (A);
4. Pull driver arm (H) back, and slip the belt between pulley (B) and shaft (E);
5. Pull idler (D) up and around (clockwise) so that the arm points to the rear of the cabinet;
6. Remove the screw from the pulley assembly, and release the pulley, belt, and retainer.

Lower Belt

1. Release the upper belt from pulleys (C) and (A) (steps 1-5 above);
2. Pull idler (G) counterclockwise and remove the lower belt from pulleys (E) and (F);
3. Pull driver arm (H) back, and slip the belt between pulley (B) and shaft (E);
4. Pull idler (G) up and around (clockwise) so that the arm points to the rear of the cabinet;
5. Remove the screw from the pulley assembly, and release the pulley, belt, and retainer.

PLACEMENT DIAGRAM

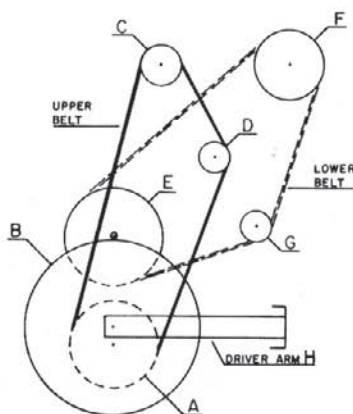

Fig. 5

Belt Replacement

To replace either belt, follow the procedures above in reverse. The upper belt must go on last. After both belts are installed, replace the Mercotac and cabinet back.

Rotosonic Drum Belt Replacement

1. Remove the middle and lower back panels of the speaker cabinet;
2. Pull the mercotac off the rotosonic drum shaft;
3. Remove both space generator belts;
4. Remove the space generator drive pulley from the rotosonic drum shaft using a 3/32" hex head Allen wrench;
5. Loosen the motor adjusting wing nuts and move the motor toward the speaker drum;
6. Remove the belt from the motor pulley;
7. Release the upper bearing assembly from the cabinet shelf, and move it up the shaft about one inch, holding the shaft in place;
8. Slip the belt around the raised bearing assembly;
9. Remove the new belt from its package, stretch it to its full length, and install it by following the above steps in reverse.
10. Adjust the belt tension so that the rotor reaches full speed in about 15 seconds.

DRIVE BELT ADJUSTMENT

Rotosonic Drum Drive Belt Adjustment

The rotor drive belt should be adjusted so that the motor pulley slips slightly on starting. The rotor should reach full speed in about 15 seconds. If it does not, loosen the motor mounting wing nuts and move the motor toward or away from the rotor to achieve the proper tension.

Treble Rotor Speed Adjustment

The motor pulley for the treble rotor has three grooves. The drive belt is normally installed in the center groove. Placing the belt in the upper groove slows the treble rotor, while placing it in the lower groove increases its speed. A spring-loaded idler maintains the proper tension on the belt, so that no tension adjustment is necessary.

Space Generator and Tremolo Generator Drive Belts

Tension on these belts is maintained by two spring-loaded idler pulleys. No adjustment is required, but the belts should be inspected occasionally for wear. See "Drive Belts".

MOTOR SERVICING

Lubrication Requirement

The motors require little lubrication. A yearly oiling is usually enough. This requirement may be increased by heavy usage or dirty operating conditions. To determine if oiling is necessary, press a clean, dry screwdriver against the felt pads around the motor bearings (2 in each motor). If oil is transferred to the screwdriver, the bearings should not be oiled. Over-oiling is just as detrimental to the motors as under-lubrication.

NOTE: Disconnect power before proceeding with this, or any other maintenance procedure.

TWO-SPEED MOTOR ASSEMBLY

Removal

1. Remove the upper and middle back panels from the speaker cabinet;
2. Disconnect the motor leads from their power cables (the small motor is connected to the white cable; the large motor to the brown);
3. Release the spring-loaded idler and slip the belt off the motor pulley;

2-SPEED MOTOR ASSY

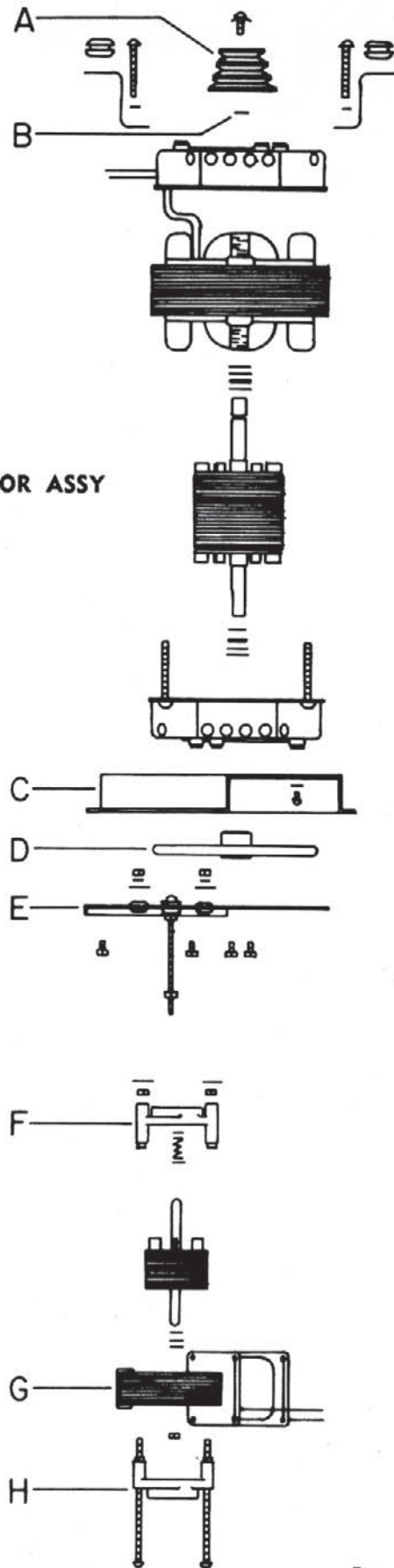

Fig. 6

4. Remove the wing nuts which hold the assembly in the cabinet;
5. Lift the motor assembly from the cabinet.
NOTE: Do not lose the bushings in the rubber grommets.

Lubrication (See Figure)

1. Remove the small motor assembly;
2. Remove the large pulley (D) using 3/32 hex (Allen) wrench;
3. Apply 8-10 drops of Electro Music Oil or other light machine oil to both bearing felts of both motors (See Figure). Do not apply more oil than the felt can readily absorb;
4. Reassemble the motor assembly, connect the power leads, and install it in the cabinet.
5. Apply 5-6 drops of oil to the oil hole near the center of the treble rotor plate.

OILING DIAGRAM

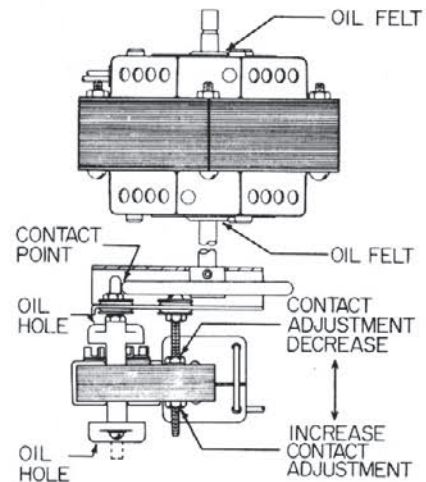

Fig. 7

Disassembly (See Figure)

1. Remove the small motor assembly;
2. Remove the large pulley (D) using 3/32 hex (Allen) wrench;
3. Remove the "U" bracket (C);
4. Remove the small pulley (A) and pulley support ring (B);
5. Mark position of the end bells in relation to the laminations to assure proper reassembly of the large motor;
6. Remove the screws which hold the large motor together and disassemble the motor;
7. Remove the small motor from its mounting bracket (E);
8. Remove the two screws in the small motor and disassemble it, noting carefully the relationship between the laminations (G) and the end bells (F & H). (Reversing the laminations will cause reverse rotation of the motor).

Cleaning

Clean the parts in solvent and allow them to dry. After the parts are completely dry, apply 8-10 drops of Electro Music oil or other light machine oil to the felt bearing pads of both motors.

Re-Assembly

The motors may be assembled by following the disassembly procedure in reverse.

NOTE: When installing the large pulley, push it on the shaft all the way, then pull it back 1/16 inch and tighten in place.

NOTE: It may be necessary to readjust the motor assembly for proper operation. See "Motor Adjustment".

Adjustment

The small motor drives the shaft of the large motor at slow speed through a rubber-tired drive pulley. The armature is spring-loaded so that it withdraws from contact with this pulley when the motor is "Off". When it is turned "On", the magnetic field of the motor forces the armature into operating position, bringing the end of the motor shaft into contact with the rubber tire. The degree of contact between the shaft and the pulley can be adjusted as follows:

1. Turn the treble rotor on at the slow speed (Celeste);
2. Turn the adjusting nuts (see figure) so that the small motor is completely disengaged from the rubber tire of the drive pulley;
3. Hold the treble horn so that it cannot move, then turn the adjusting nuts until the small motor forces the pulley to turn under the belt;

NOTE: Avoid excessive pressure on the rubber tire.

4. Run-test the motor. Excessive noise may mean that the bearings of the large motor are misaligned. Tap the motor laminations lightly with a hammer to seat them.

SINGLE-SPEED MOTOR

Lubrication

The motor which drives the roto-sonic drum may be lubricated by removing the lower back panel and applying 8-10 drops of Electro Music Oil, or another light machine oil to the felt bearing pads (See Figure). Do not apply more oil than the felt can readily absorb.

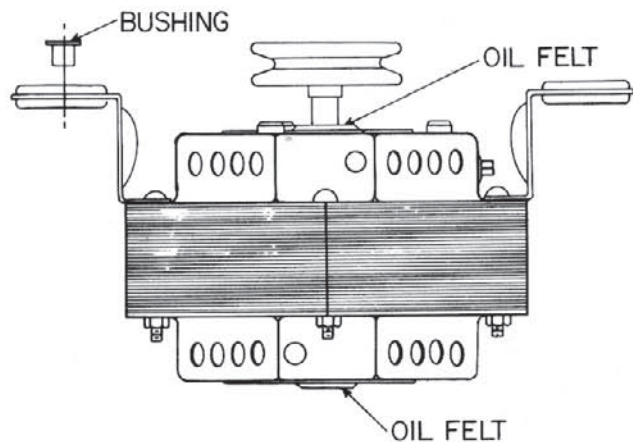

Fig. 8

Removal

1. Remove the lower back section of the speaker cabinet;
2. Unplug the motor from the power supply;
3. Supporting the motor by hand, remove the wing nuts which hold the motor, and slip off the drive belt;
4. Remove the motor from the cabinet, being careful not to lose the bushings inside the motor bracket grommets (See Figure above).

Disassembly

1. Remove the screws which hold the motor assembly together;
2. Remove the closed end bell (L);
3. Remove the motor pulley (C) and pulley support ring (D);

4. Remove the armature (J) from the drive end bell (F) and remove the washers (I) from the armature;
5. Remove the drive end bell from the laminations.

Cleaning

Clean the motor parts with solvent and allow them to dry. After the parts are completely dry, apply 8-10 drops of Electro Music oil to the felt pads on both end bells.

Re-Assembly

1. Place the armature washers (I) on the long shaft of the armature (J);
2. Insert the long shaft of the armature into the drive end bell (F);
3. Replace the snap ring (D) and motor pulley (C) on the long armature shaft, and tighten the screw (A);
4. Route the motor wires (G) through the wire hole in the drive end bell (F), and position the laminations (H) on the guide pins on the end bell so that the wires do not wrap around the armature;
5. Position the closed end bell (L) on the laminations, over the guide pins;
6. Install the motor brackets (E) and tighten the screws and nuts. Note that one of the brackets faces the wire hole in the drive end bell.

SINGLE-SPEED MOTOR

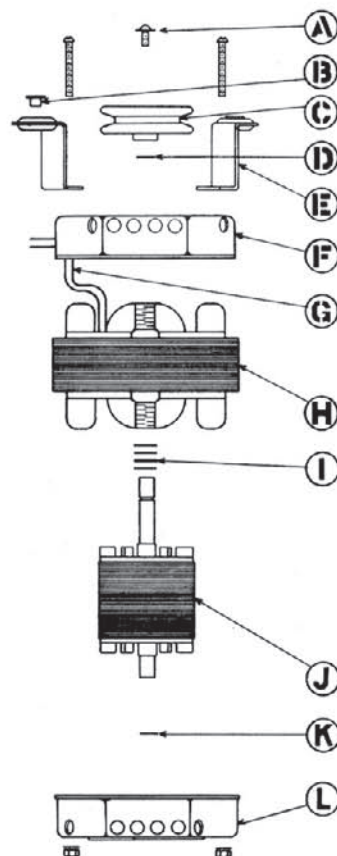

Fig. 9

Installation

1. Install the motor on the mounting screws, but do not tighten the wing nuts;
2. Plug the motor cable into the "Drum" receptacle on the power supply;

3. Run-test the motor. Excessive noise may mean that the motor bearings are misaligned. Tap the motor laminations lightly with a hammer to seat the bearings.
4. Install the drive belt on the speaker drum pulley and then on the motor pulley;
5. Adjust the belt tension so that full speed is attained in about 15 seconds and tighten the wing nuts;
6. Replace the back panel.

TWO CIRCUIT ROTARY CONTACT (MERCOTAC)

The mercotac is a noiseless two-circuit rotary contact assembly which provides the electrical connection for the speaker in the rotonic drum. It uses mercury as a contact medium to avoid the noise usually produced by sliding contacts. If the contact assembly is jarred or inverted, the mercury may be dislodged from its well in the base of the contact, and the rotating speaker will become noisy or inoperative.

Checking The Two Circuit Rotary Contact

1. While holding the two circuit rotary contact in an upright position, spin the top center section with the fingers three or four times.
2. Using an ohmmeter, check to see that there is complete continuity between both the top and bottom center contacts and the top and bottom outside contacts. (Meter should read less than one ohm.)
3. Check to see that there is *no* continuity between the center and outside contacts. If continuity is found, and the repetition of step number 1 does not clear the contact, reseal the mercury, using the same technique as is used to clear a fever thermometer.

Hold the unit with the fingertips, with the funnel-shaped end pointing away from the palm of the hand. Then apply centrifugal force by combining a smooth downward swing of the arm with a final wrist-snap motion. If this does not clear the contact, it is probably defective and should be replaced.

Replacing the Two-Circuit Rotary Contact

1. Remove the plastic cap assembly from the top of the rotary contact by pulling straight up;
2. Remove rotary contact from rotor shaft; twist and pull up;
3. Replace rotary contact on shaft by pushing straight down carefully to prevent damage to contact pin in center of shaft;

NOTE: Rotary contact *must* be inserted with arrow pointed up as shown on contact unit.

4. Replace the plastic cap.

NOTE: This contact assembly contains mercury. If a mercotac is defective, it should be discarded. It should not be disassembled or subjected to high heat which may vaporize the mercury.

ROTONIC DRUM REMOVAL

1. Remove the lower and middle back panels from the speaker cabinet;
2. Remove the 15-inch bass speaker;
3. Remove the rotary contact (mercotac);
4. Remove the space generator belts;
5. Remove the eccentric idler pulley assembly;
6. Remove the drive pulley from the rotor shaft;
7. Loosen the motor adjusting wing nut and move the motor toward the rotor;

NOTE: It is not necessary to remove the motor from the cabinet.

8. Remove the rotor drive belt;
9. Remove the upper bearing block assembly;
10. Remove the speaker wires from the sockets on the rotor pulley shaft;
11. Pull the rotor shaft up and remove it from the speaker drum;
12. Remove the drum from the cabinet.
13. To reinstall the rotor assembly, reverse the above procedure, noting special instructions below:
 - A. When installing the shaft into the drum and lower bearing, be very careful not to dislodge the grommets. Oil or vaseline may be used to lubricate the shaft, as the grommets are neoprene.
 - B. Adjust the drive belt tension so that the rotor comes to full speed in about 15 seconds.
 - C. If the speaker is noisy or does not operate, refer to the section: "Two-Circuit Rotary Contact".

SPEAKER REPLACEMENT

Because of the extremely strong magnetic fields in the loudspeakers, it is inadvisable to attempt cone replacements or any other repairs involving their disassembly. Repair or replacement of loudspeakers should be arranged through Electro Music.

Treble Speaker

1. Remove the upper back panel;
2. Remove the treble rotor belt;
3. Disconnect the clips on the treble speaker wires;
4. Remove the three screws in the rim of the treble speaker unit, and drop the speaker unit straight down and out of the cabinet. The upper tremulant rotor may be removed, if desired, by turning it sideways.

IMPORTANT: When replacing these parts, be sure the rubber and metal thrust washers are on the spindle, so that the tremulant rotor will operate at the correct height, and bass tones will not produce thrust bearing noises. The rubber washer is placed on the spindle first, and the metal washer rides on top of it.

Horn Reflector Replacement

Cut the stand-off pins and pull them out with a pair of slip joint or "gas" pliers. When installing the new reflector, put it on so the cut edge is at the top of the horn when it is in operating position. To hold the reflector without rattling, use the special cement furnished by Electro Music.

Non-Vibrato Speakers

1. Remove the upper back panel;
2. Remove the speaker leads from the speakers;
3. Remove the nuts which hold the speakers, and carefully remove them from the cabinet.

Bass Speaker

1. Remove the center back panel;
2. Unclip the speaker leads;
3. Remove the seven screws holding the speaker;
4. Lift the speaker straight up to avoid snagging the cone on the brackets under it.

Percussion Speaker

1. Remove the lower back panel;
2. Remove the power supply;
3. Remove the lower motor;
4. Remove the three long screws that hold the percussion speaker housing in place;
5. Unclip the speaker leads;
6. Remove the nuts holding the percussion speaker.

CAUTION

When reinstalling speakers, observe correct polarity. Note the large and small pins, and male and female lugs on the speaker connectors.

AMPLIFIER HEAT SINK 031096

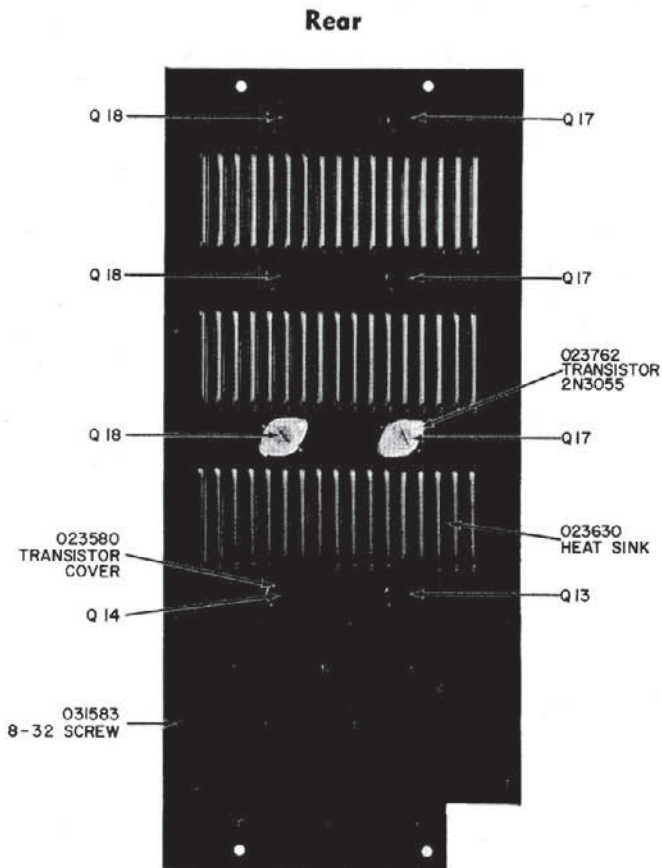

Fig. 10A

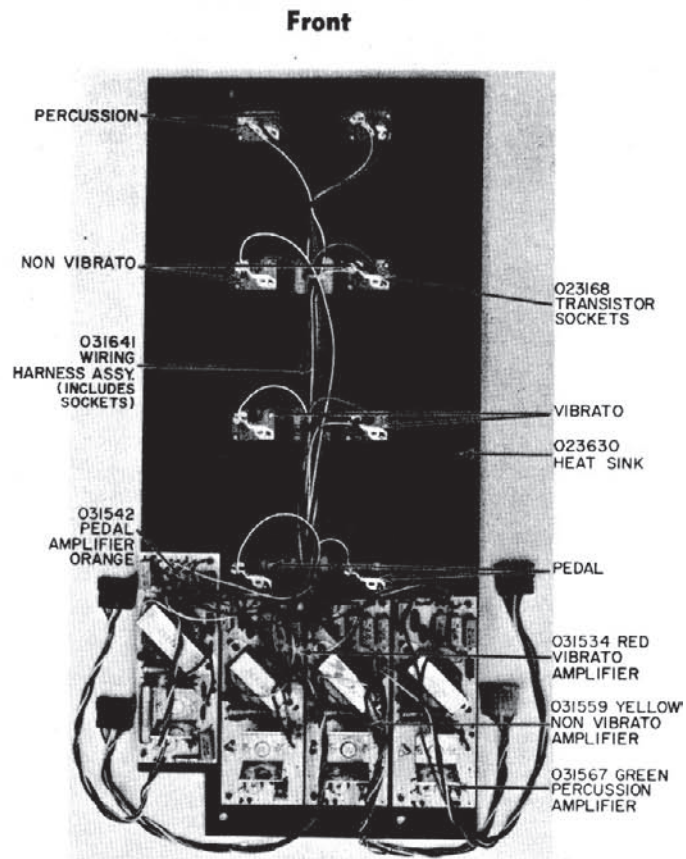

Fig. 10B

Rotary Speaker

1. Remove the rotononic drum (see p. 8)
2. Turn the rotor upside down, exposing the speaker access opening in the bottom of the drum.
3. Remove the four mounting screws and carefully lift out the speaker.

THE AMPLIFIER

The 4-channel amplifier in the X-77L is engineered for long, trouble-free operation. Solid-state circuits are used throughout. The power supply employs a heavy-duty power transformer and silicon rectifiers.

Each channel of the amplifier is mounted on a separate circuit board. The four circuit boards are mounted on the anodized lower back panel of the speaker cabinet, which serves as a heat sink for the output transistors.

The amplifier leads are long enough to allow the back panel to be laid flat for servicing. The printed circuit boards can be removed from the heat sink and turned over without being disconnected from the circuit. If a circuit board is defective, it can easily be replaced as a complete unit.

NOTE: Although the low voltages employed in the power amplifier considerably reduce the shock hazard involved in working on these circuits while they are operating, shorting the conductors on the printed circuit board together may severely damage the components on the board, or even the board itself.

Circuit Board Replacement

1. Unplug the cables connecting the circuit board to the power supply;
2. Unsolder the leads connecting the wiring harness from the board to the output transistors;
3. Remove the four 8-32 nuts and washers that hold the board to the amplifier panel;
4. Install the new circuit board on the mounting studs, and follow the above steps in reverse to complete the installation.

**PEDAL AMP
031542**

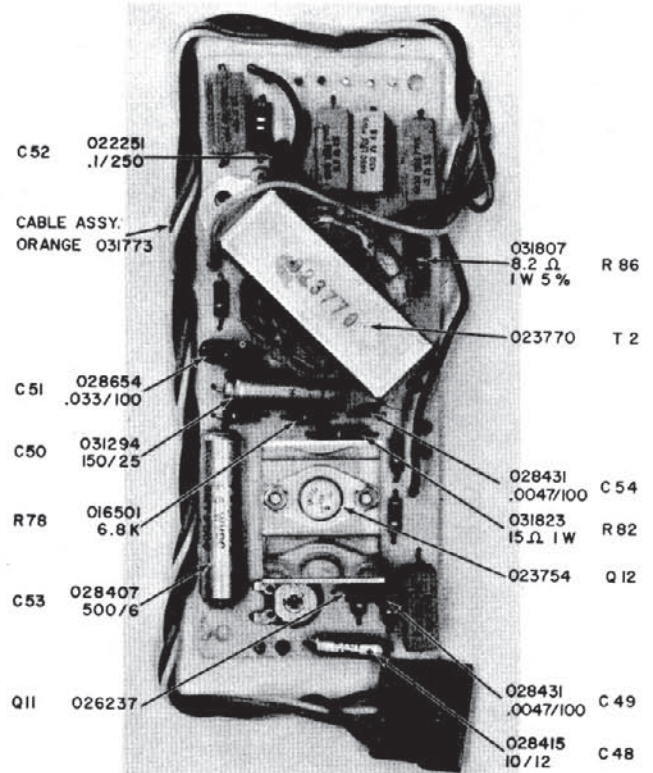
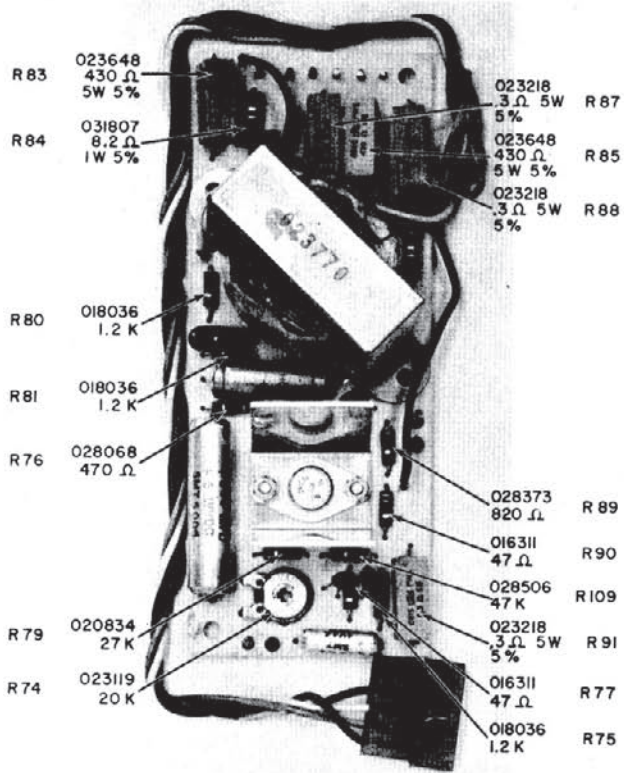

Fig. 11A

Fig. 11B

**Vibrato
031534**

**Non-Vibrato
031559**

**Percussion
031567**

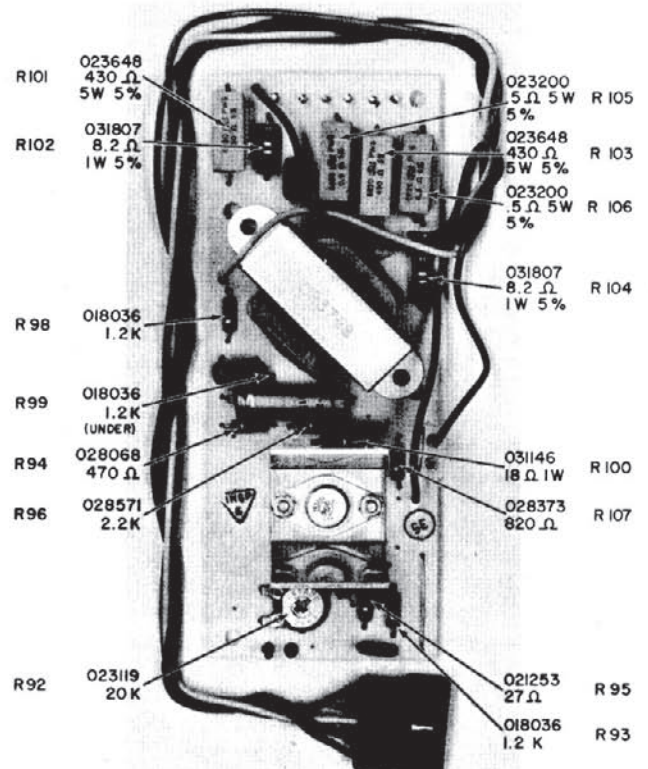
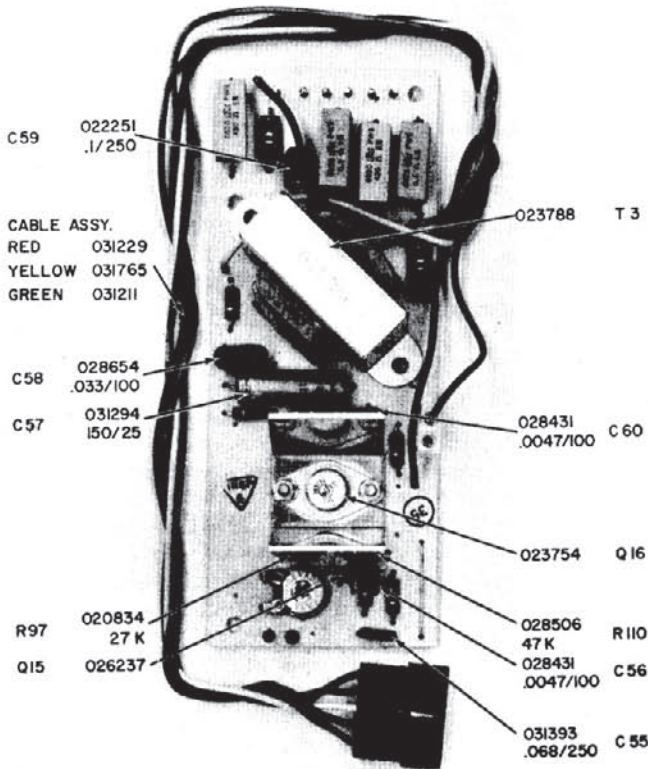

Fig. 12A

PEDAL AMP CIRCUIT BOARD

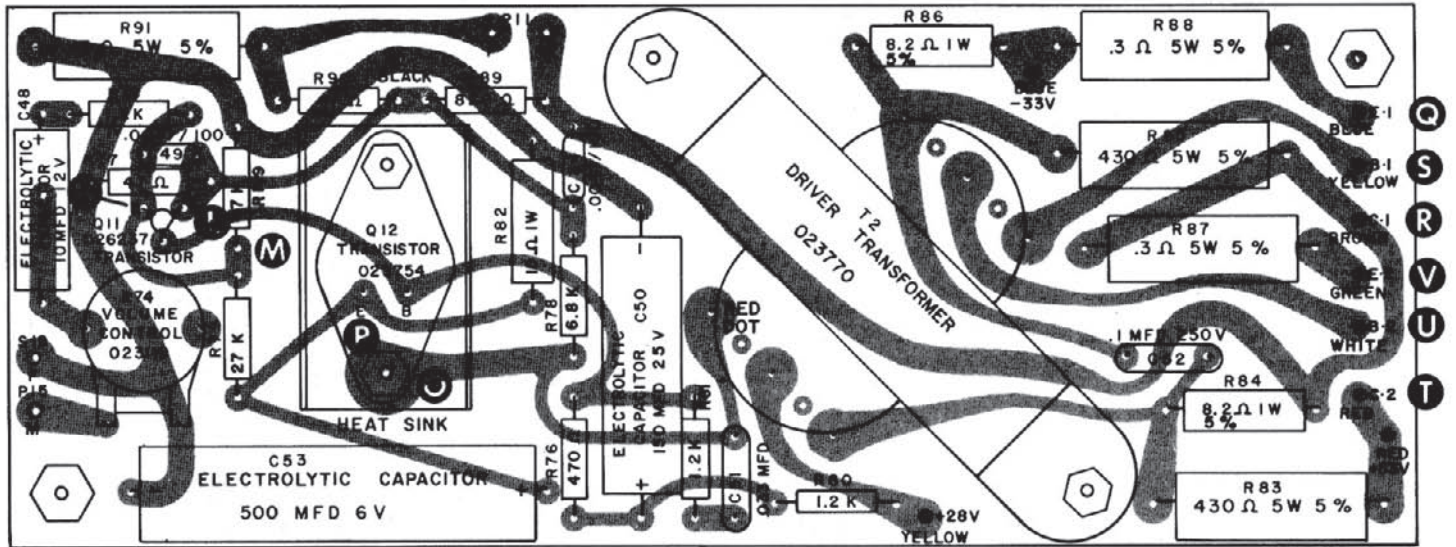

Fig. 13

Servicing

As the three manual amplifiers are identical in all respects, it is easy to substitute one for another for testing purposes. Transfer all plugs from the inoperative channel to one of the other circuit boards. If the channel functions properly after the exchange of plugs, its amplifier may be defective, and the circuit board should be checked.

Pedal Amplifier Voltages

L	+0.4	R	0
M	+3	S	Note
N	+1	T	+33
O	+25	U	Note
P	+2.4	V	Note
Q	Note		

Note: 0.5V difference between Q-S, U-V.

VIBRATO NON-VIBRATO PERCUSSION AMPLIFIER CIRCUIT BOARD

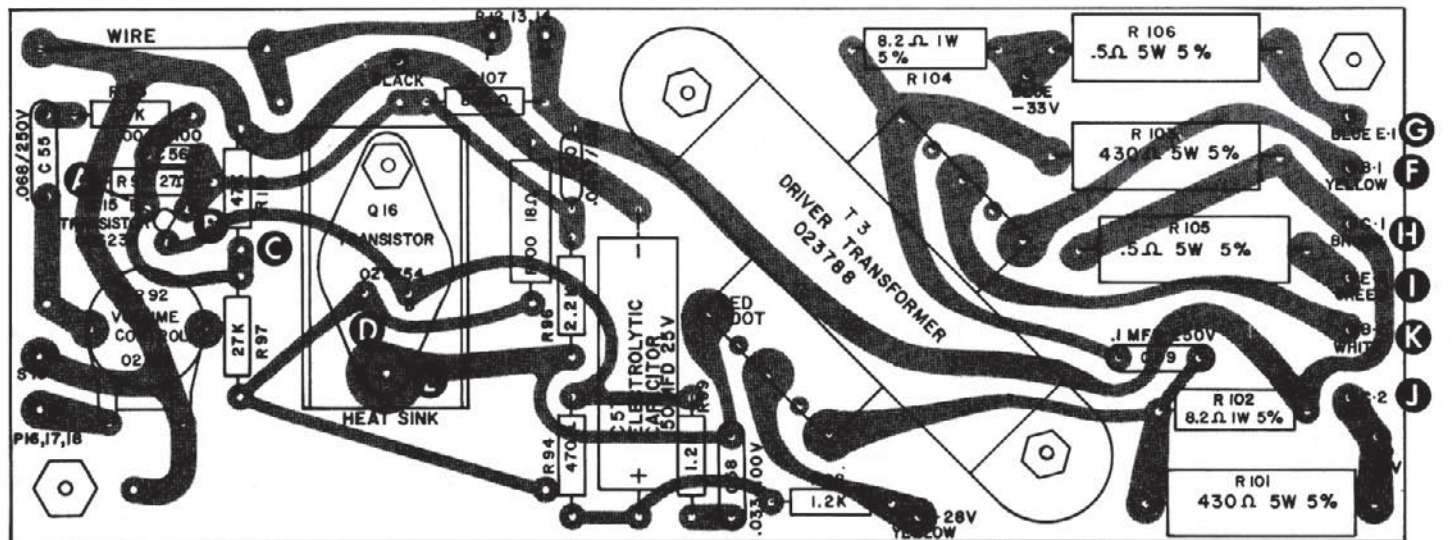

Fig. 14

Voltage Checks

Remove the circuit board in question from the heat sink (4 nuts) and fasten the black ground wire from the power supply to its ground terminal. Check the voltages on the board against the various test points indicated on the circuit board drawing. The voltages given are approximate, and will vary $\pm 10\%$ under normal "no-signal" operating conditions. Measurements should be made to power supply ground with a 20K ohm/volt meter.

Manual Amplifier Voltages

A	+1.3	G	-33
B	+0.7	H	0
C	+3.3	I	Note
D	+2.9	J	+33
E	+27	K	Note
F	Note		

Note: 0.5V difference between F-G, I-K.

SPACE GENERATOR/TREMOLO GENERATOR

The space generator must be removed if one of the circuit boards, or a variable capacitor needs replacement. The circuit boards are very complex, and it is difficult to repair them in the field. If a circuit board is defective, it is advisable to replace it with another complete board, available from your local dealer, or from Electro Music.

Removal

1. Remove the space generator drive belts;
2. Remove the three wing nuts and washers that hold the space generator in place;
3. Lift the space generator off its mounting studs.

NOTE: The power should be turned OFF when the space generator plug is removed from the power supply.

Circuit Board Replacement

1. Remove the metal cover (four screws);
2. Remove the wires clipped to the edge of the circuit board;
3. Remove the four nuts and washers that hold the circuit board to the capacitor stators, and lift the board off;
4. To install a new board, follow the above steps in reverse. Be sure the capacitor shaft makes positive contact with the graphite button on the board.

Variable Capacitor Replacement

1. Remove the circuit board from the defective capacitor;
2. Remove the pulley from the rotor shaft;
3. Remove the two sheet metal screws that hold the masonite base plate of the capacitor to the metal chassis;
4. To install a new capacitor, follow the above steps in reverse. Be sure capacitor shaft makes positive contact with the graphite button on the board.

SPACE GENERATOR 022756

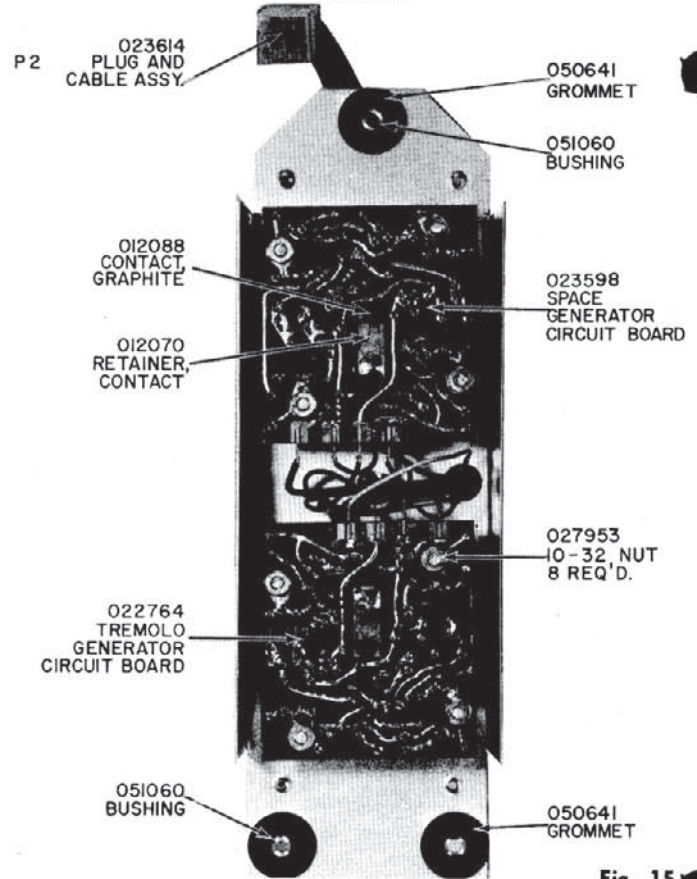

Fig. 15

NOTE: Always observe the following color code when reconnecting the circuit boards:

Black	Ground
Red	B+
Red, Shielded	Space Generator input
Green	Space Generator output
Gray, Shielded	Tremolo Generator input
White	Tremolo Generator output

SPACE GENERATOR BOARD

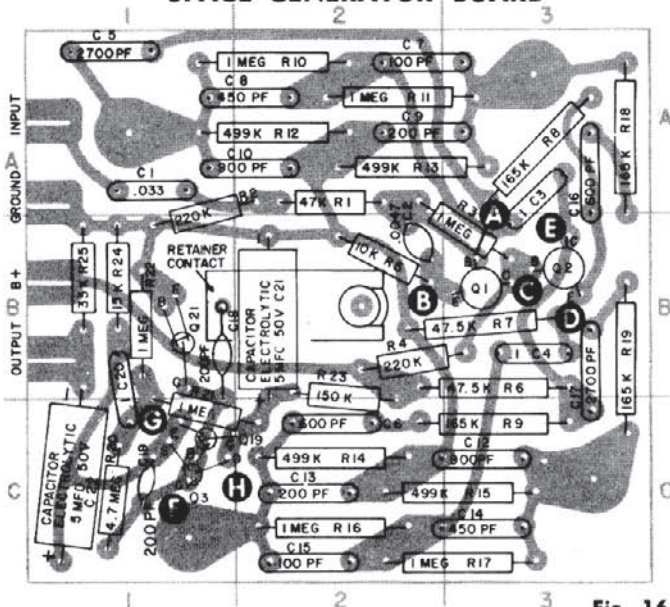

Fig. 16

TREMOLO GENERATOR BOARD

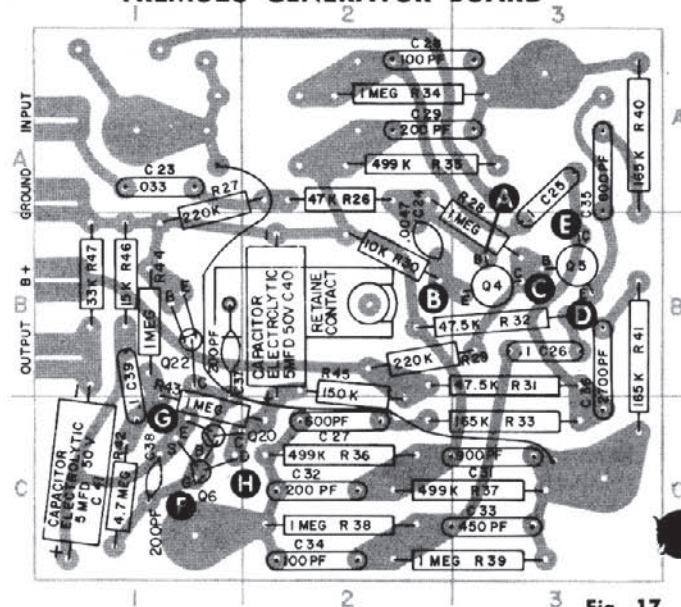

Fig. 17

SPACE GENERATOR PARTS LIST

Part	Location	Description	Part No.	Part	Location	Description	Part No.
R1	A2	47K	Resistor 028506	C2	B2	.0047 μ f @ 100V	Capacitor 028431
R2	A2	220K	Resistor 013615	C3	A3	0.1 μ f @ 250V	Capacitor 022251
R3	B3	1.°MEG	Resistor 024125	C4	B3	0.1 μ f @ 250V	Capacitor 022251
R4	B2	220K	Resistor 013615	C5	A1	2700Pf @ 500V	Capacitor 024059
R5	B2	10K	Resistor 028548	C6	C2	600Pf @ 500V	Capacitor 024034
R6	B3	47.5K, ½W, 1%	Resistor 024109	C7	A2	100Pf @ 500V	Capacitor 024000
R7	B3	47.5K, ½W, 1%	Resistor 024109	C8	A2	450Pf @ 500V	Capacitor 024026
R8	A3	165K, ½W, 1%	Resistor 024091	C9	A2	200Pf @ 200V	Capacitor 024018
R9	C3	165K, ½W, 1%	Resistor 024091	C10	A2	900Pf @ 500V	Capacitor 024042
R10	A2	1. MEG, ½W, 1%	Resistor 024075	C12	C3	900Pf @ 500V	Capacitor 024042
R11	A2	1. MEG, ½W, 1%	Resistor 024075	C13	C2	200Pf @ 500V	Capacitor 024018
R12	A2	499K, ½W, 1%	Resistor 024083	C14	C3	450Pf @ 500V	Capacitor 024026
R13	A2	499K, ½W, 1%	Resistor 024083	C15	C2	100Pf @ 500V	Capacitor 024000
R14	C2	499K, ½W, 1%	Resistor 024083	C16	A3	600Pf @ 500V	Capacitor 024034
R15	C3	499K, ½W, 1%	Resistor 024083	C17	B3	2700Pf @ 500V	Capacitor 024059
R16	C2	1. MEG, ½W, 1%	Resistor 024075	C18	B1	200Pf @ 1KV	Capacitor 023622
R17	C3	1. MEG, ½W, 1%	Resistor 024075	C19	C1	200Pf @ 1KV	Capacitor 023622
R18	A3	165K, ½W, 1%	Resistor 024091	C20	B1	0.1 μ F @ 250V	Capacitor 022251
R19	B3	165K, ½W, 1%	Resistor 024091	C21	B2	5 μ F @ 50V	Capacitor 028589
R20	C1	4.7 MEG	Resistor 013623	C22	C1	5 μ F @ 50V	Capacitor 028589
R21	C1	1. MEG	Resistor 024125	Q1	B3	2N3440, NPN	TSTR 022939
R22	B1	1. MEG	Resistor 024125	Q2	B3	2N3440, NPN	TSTR 022939
R23	B2	150K	Resistor 028357	Q3	C1	2N5163, FET	TSTR 023606
R24	B1	15K	Resistor 048157	Q19	C1	2N3859A, NPN	TSTR 061366
R25	B1	33K	Resistor 028522	Q21	B1	2N3859A, NPN	TSTR 061366
C1	A1	.033 μ f @ 100V	Capacitor 028654			Unless otherwise specified, all resistors are ½ watt, 10%	

TREMOLO GENERATOR PARTS LIST

Part	Location	Description	Part No.	Part	Location	Description	Part No.
R26	A2	4.7K	Resistor 028506	C24	B2	.0047 μ FD	Capacitor 028431
R27	A2	220K	Resistor 013615	C25	A3	.1 @ 250V	Capacitor 022251
R28	B3	1 MEG	Resistor 024125	C26	B3	.1 @ 250V	Capacitor 022251
R29	B2	220K	Resistor 013615	C27	C2	600PF	Capacitor 024034
R30	B2	10K	Resistor 028548	C28	A2	100PF	Capacitor 024000
R31	B3	47.5K	Resistor 024109	C29	A2	200PF	Capacitor 024018
R32	B3	47.5K	Resistor 024109	C31	C3	900PF	Capacitor 024042
R33	C3	165K, ½ watt, 1%	Resistor 024091	C32	C2	200PF	Capacitor 024018
R34	A2	1 MEG	Resistor 024125	C33	C3	450PF	Capacitor 024026
R35	A2	499K	Resistor 024083	C34	C2	100PF	Capacitor 024000
R36	C2	499K	Resistor 024083	C35	A3	600PF	Capacitor 024034
R37	C3	499K	Resistor 024083	C36	B3	2700PF	Capacitor 024059
R38	C2	1 MEG	Resistor 024125	C37	B1	200PF	Capacitor 024018
R39	C3	1 MEG	Resistor 024125	C38	C1	200PF	Capacitor 024018
R40	A3	165K, ½ watt, 1%	Resistor 024091	C39	B1	.1 MFD @ 250V	Capacitor 022251
R41	B3	165K, ½ watt, 1%	Resistor 024091	C40	B2	5 μ FD @ 50V	Capacitor 028589
R42	C1	4.7 MEG	Resistor 013623	C41	C1	5 μ FD @ 50V	Capacitor 028589
R43	C1	1 MEG	Resistor 024125	Q4	B3	2N3440 NPN	TSTR 022939
R44	B1	1 MEG	Resistor 024125	Q5	B3	2N3440 NPN	TSTR 022939
R45	B2	150K	Resistor 028357	Q6	C1	2N5163 FET	TSTR 023606
R46	B1	15K	Resistor 048157	Q20	C1	2N3859A NPN	TSTR 061366
R47	B1	33K	Resistor 028522	Q22	B1	2N3859A NPN	TSTR 061366
C23	A1	.033 μ FD	Capacitor 028654				

POWER SUPPLY

The power supply chassis houses the speaker control and crossover circuits, as well as the low and high voltage DC supplies. Four color-coded, five-contact sockets receive the power and audio cables from the amplifier circuit boards. The input leads for the amplifiers emanate from the power supply and terminate in single-contact sockets. These sockets engage contact pins at the circuit boards.

The power plugs and signal wires observe the following color code:

Black Ground Wire
 Red Vibrato Channel
 Orange Pedal Channel
 Yellow Non-Vibrato Channel
 Green Percussion Channel

The motor controls are also located in the power supply. The motor cable color code is:

Brown Fast Motor, upper rotor
 White Slow Motor, upper rotor
 Brown Drum Motor

Removal

1. Remove the lower back panel;
2. Disconnect the four input leads, the four speaker leads, and the ground lead from the amplifier chassis;
3. Unplug the four amplifier cables, the three motor cables, and the space generator cable from the power supply;

NOTE: The power should be turned OFF when the plugs are removed.

4. Remove the three long screws which secure the power supply to the bottom shelf;
5. Slide the power supply out of the cabinet.
6. To replace the power supply, follow the steps above in reverse.

POWER SUPPLY, BOTTOM

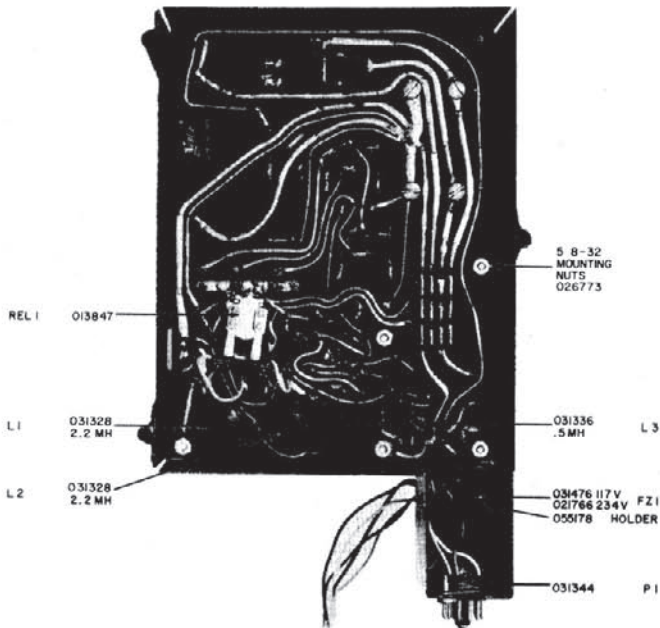
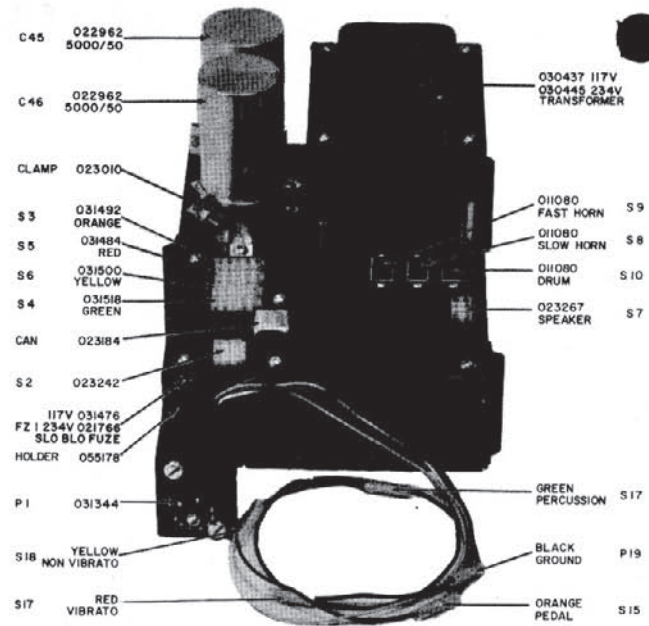

Fig. 21

POWER SUPPLY 031088 117 VAC/030676 234-250 VAC



NOTE:
 S15 THRU S18 USES 023572 HOUSING AND 023556 INSERT
 P19 USES 023572 HOUSING AND 023309 INSERT

Fig. 20

Circuit Board Removal

1. Remove the power supply from the cabinet;
2. Unplug the amplifier and motor leads from the chassis;
3. Remove the six screws that secure the three 117-volt receptacles;
4. Turn the chassis over;
5. Remove the four panhead screws that fasten the circuit board to the large electrolytic capacitors;
6. Remove the five 10-24 nuts and lockwashers, and carefully lift the circuit board clear of the studs;
7. Set the circuit board on edge in the chassis to remove or replace components.
8. To replace the circuit board, follow the steps above in reverse. Do not tighten any of the nuts or screws until all of them have been started.

TRANSISTOR VOLTAGES DC

NO.	CELESTE			NON CELESTE		
	E	B	C	E	B	C
Q 7	-12	-11	-11	-12	-12	0
Q 8	-12	-12	0	-12	-11	-11
Q 9	-12	-11	-11	-12	-12	0
Q 10	-12	-12	0	-12	-11	-11

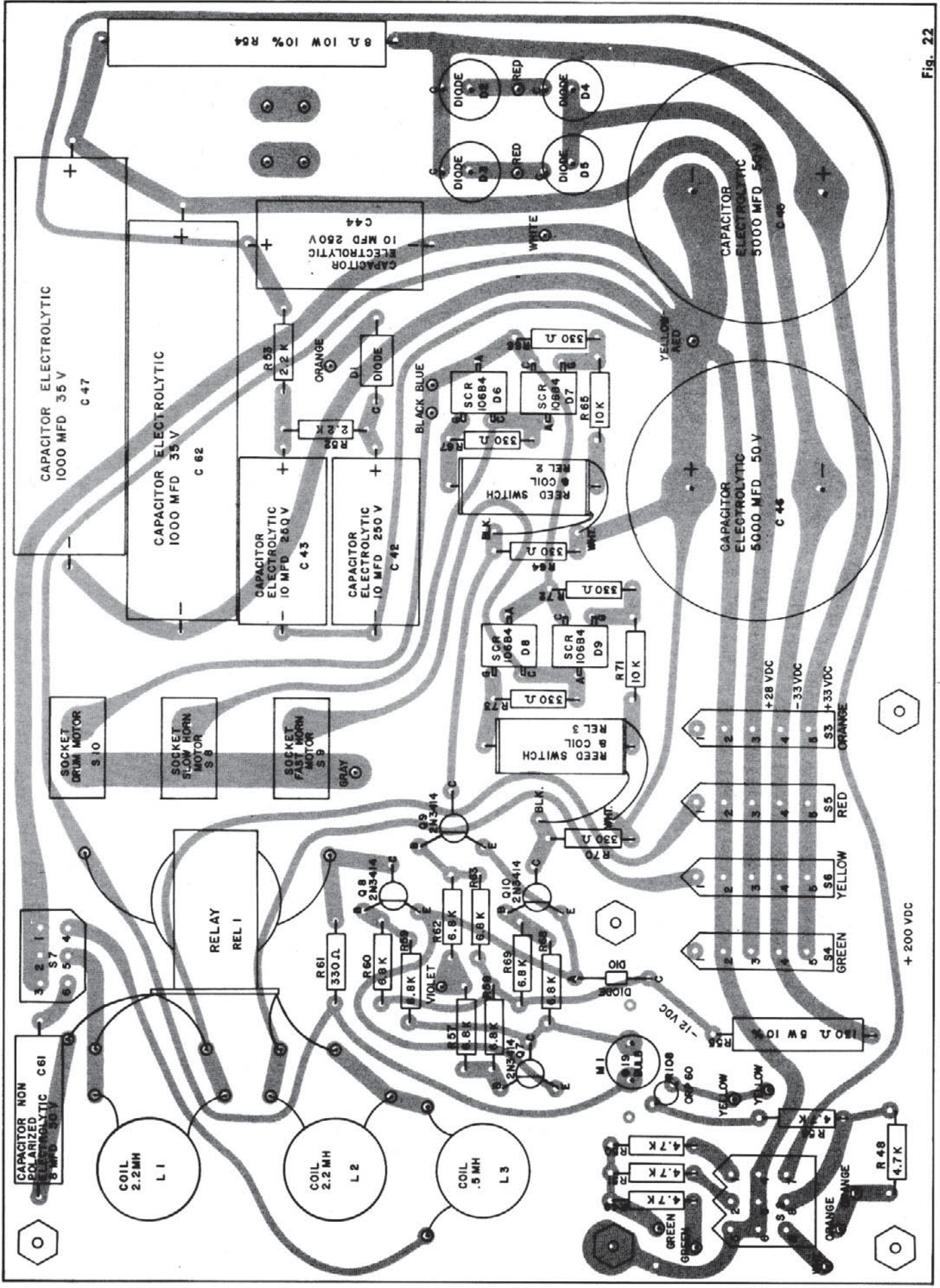

Fig. 22

POWER SUPPLY CIRCUIT BOARD

POWER SUPPLY

